

NOTES:
 ALL STEEL CONSTRUCTION
 PART NUMBERS:
 13201.100 - PAINTED
 13201.120 - GALVANIZED
 13201.130 - POWDER COATED

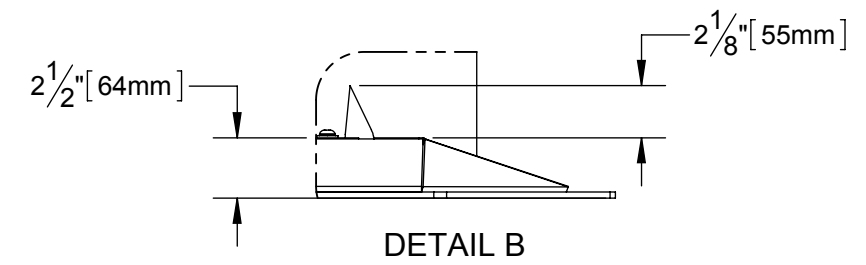
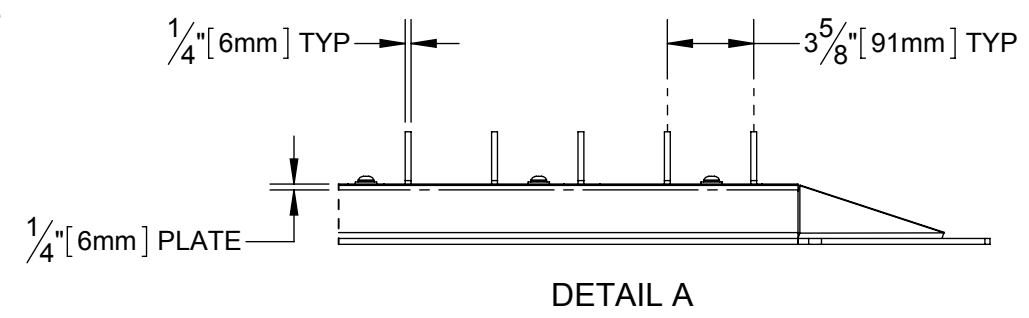
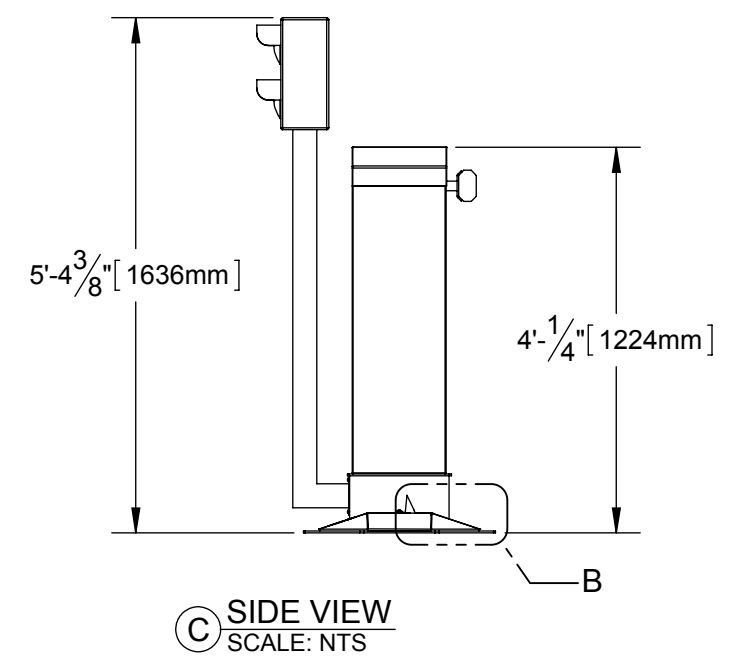
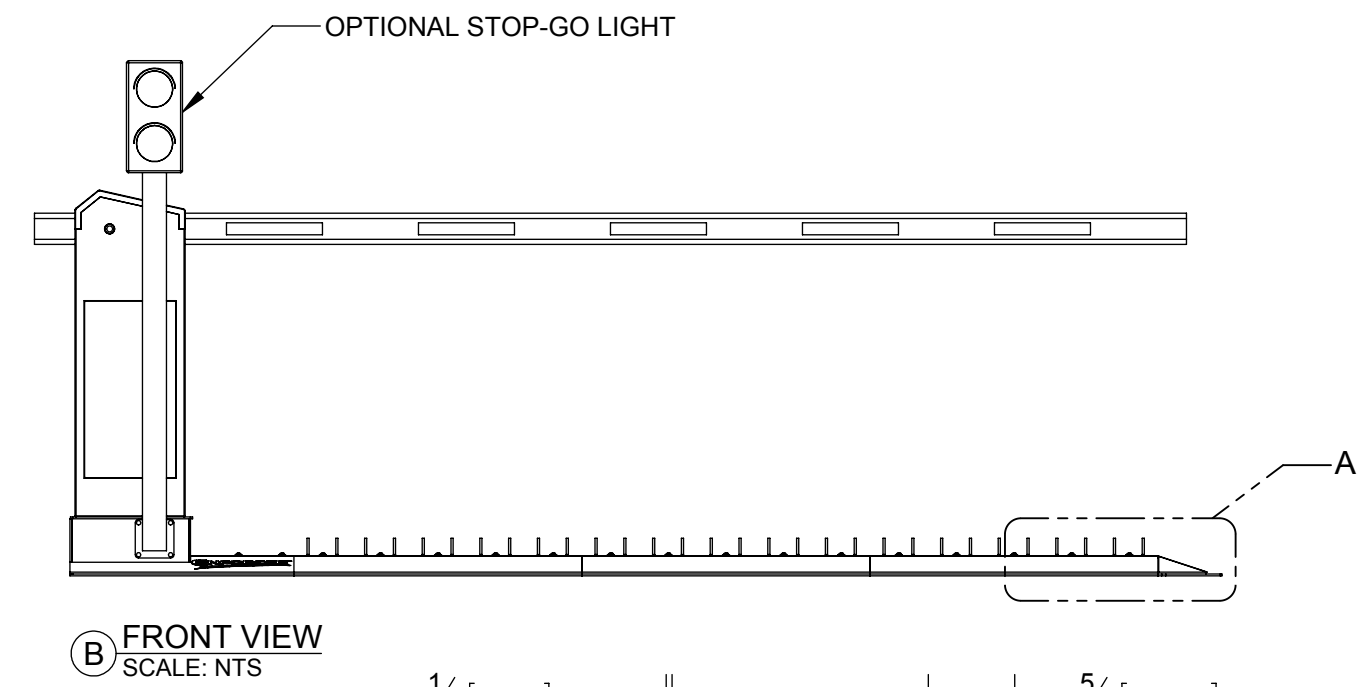
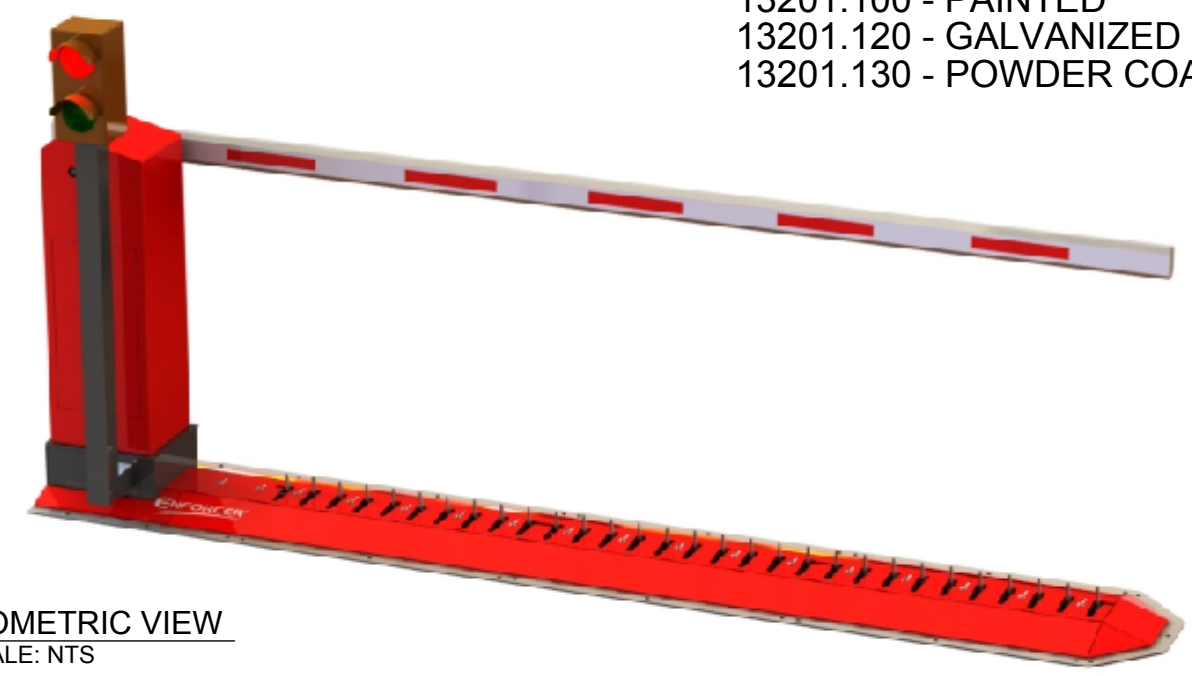
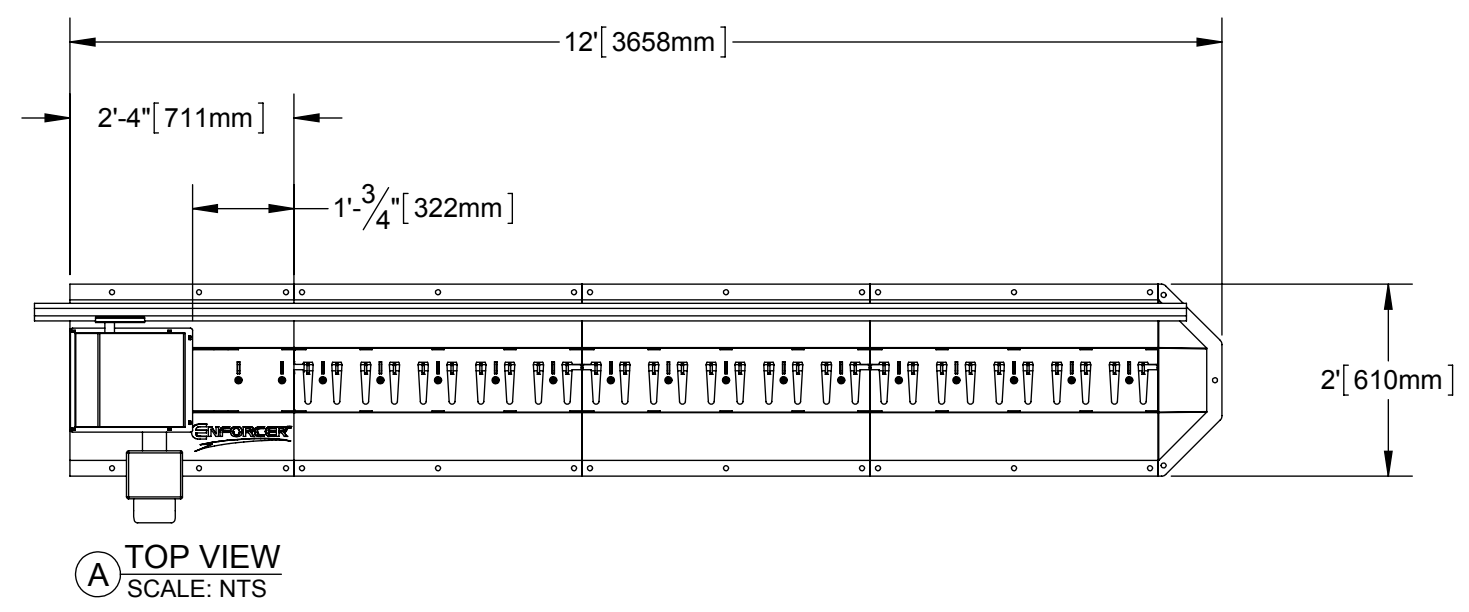

Secure Lane
 www.secure-lane.com
 520.780.9751

UNLESS OTHERWISE SPECIFIED:		MATERIAL:		SIZE	PART NUMBER	REV	DESCRIPTION
DIMENSIONS ARE IN INCHES		N/A		B	13201	-	ENFORCER 12' (3.5M)
FRACTIONAL: ± 1/8"		DO NOT SCALE DRAWING	NAME	DATE	WEIGHT: N/A	SHEET 1	MOTORIZED SURFACE
ANGULAR: MACH ± 1°		DRAWN	RLS	11/27/13	SCALE: N/A		TRAFFIC SPIKE SYSTEM
TWO PLACE DECIMAL ±.01							
THREE PLACE DECIMAL ±.005							